



**ROAD PLANING, SOIL STABILIZATION,
RECLAIMING, GRADING,
TRENCHING AND FOUNDATION DRILLING BITS**

REV 01-20

15020 INDUSTRIAL PARK ROAD | BRISTOL, VA USA | (276)-644-3520 | WWW.JENMAR.COM

JENNMAR Locations

USA

GLOBAL HEADQUARTERS

Pittsburgh, PA
PH: 412-963-9071
FX: 412-963-9767

KENTUCKY

Winchester, KY
PH: 859-744-9600
FX: 859-745-4028

Earlington, KY
PH: 270-383-3171
FX: 270-383-3121

PENNSYLVANIA

Office
Cresson, PA
PH: 814-886-4121
FX: 814-886-8143

Bolt Plant
Cresson, PA
PH: 814-886-5485
FX: 814-886-4598

UTAH

Clearfield, UT
PH: 801-775-0176
FX: 801-775-0188

Tooele, UT
PH: 801-973-7169
FX: 801-913-7172

VIRGINIA

Pounding Mill, VA
PH: 276-964-2107
FX: 276-963-5928

Rich Creek, VA
PH: 540-726-2326
FX: 540-726-7340

WEST VIRGINIA

Reedsville, WV
PH: 304-864-3601
FX: 304-864-4169

GLOBAL

JENNMAR AUSTRALIA

Main Office and Plant
Sydney, NSW
PH: +61 2-4648-7500
FX: +61 2-4648-7555

Mackay, QLD
PH: +61 7-4952-8700
FX: +61 7-4952-8777

Landsdale, WA
PH: +61 8-9408-9900
FX: +61 8-9408-9999

AFFILIATES

J-LOK

Cresson, PA
PH: 814-886-7590
FX: 814-886-7695

Earlington, KY
PH: 270-326-3660
FX: 270-383-5670

KMS - KEYSTONE MINING SERVICES

Pittsburgh, PA
PH: 412-963-9071
FX: 412-963-8812

JENNCHEM

Pittsburgh, PA
PH: 412-963-9071
FX: 412-963-7179

JENNCHEM MID-WEST

J-PAK Plant
Marion, IL
PH: 618-889-5474
FX: 618-364-3515

JM CONVEYOR

Lebanon, VA
PH: (276) 883-5200
FX: (276) 883-5199

Blairsville, PA
PH: 724-459-5261
FX: 724-459-0865

JM STEEL

Huger, SC
PH: 843-336-4929
FX: 843-336-4935

JENNMAR SPECIALTY CEDAR BLUFF

Cedar Bluff, VA
PH: 276-964-7413
FX: 276-963-9389

JENNMAR SPECIALTY PRODUCTS

Cedar Bluff, VA
PH: 276-964-7000
FX: 276-964-4752

JENNMAR CIVIL

Pittsburgh, PA
PH: 412-963-9071
FX: 412-963-9767

XCAL TOOLS

South Point, OH
PH: 740-377-3354
FX: 740-377-3363

Oak Hill, WV
PH: 304-465-0651
FX: 304-469-9838

Madisonville, KY
(formerly Cuda)
PH: 270-825-BITS (2487)

Bristol, VA
PH: 276-644-3520

XCAL INDUSTRIES

Oak Hill, WV
PH: 304-469-4721
FX: 304-469-4750

JENNMAR SERVICES

Corporate East Headquarters
Canonsburg, PA
PH: 724-514-7656

Corporate West Headquarters
Delta, CO
PH: 970-874-5256

Corporate Midwest Headquarters
Macedonia, IL
PH: 618-364-3500

Sales Contacts

GLOBAL HEADQUARTERS

Rodney Poland VP Sales & Technical Resources (304) 276-5537	Jimmy Hull Regional Sales Manager – Eastern Region (304) 312-9539	Ray Wilson Regional Sales Manager – Midwest (205) 790-4259	Todd Young Regional Sales Manager - West (276) 971-3687	Art Craven Wire Mesh Manager (970) 260 - 2495
--	--	---	--	--

PLANT LOCATIONS

CRESSON, PA Jimmy George Technical Sales Representative (814) 418-5268	WINCHESTER, KY (EAST) Kris Kirkpatrick Technical Sales Representative (618) 294-2101	CEDAR BLUFF, VA/ RICH CREEK, VA Richie Belcher Technical Sales Representative (340) 784-4996	Troy Timothy Technical Sales Representative Hard Rock Division (775) 299-9299
Robert Leretis Material Manager Representative (440) 813- 6434	Chas Johnson Technical Sales Representative (606) 309-5118	Brandon Stables Technical Sales Engineer (304) 923-5025	Ron Key Technical Sales Representative (970) 317-1640
REEDSVILLE, WV Perry Huggins Technical Sales Representative (304) 282-7175	EARLINGTON, KY (WEST KY) Jeremy Shoulders Technical Sales Representative (270) 227-3791	CEDAR BLUFF, VA (SPECIALTY PRODUCTS) John Breedlove General Manager (276) 964-7413	Brady Weekly Technical Sales Representative Hard Rock Division (412) 925-0876
Dennis Richards Technical Sales Engineer (304) 923-7778	Jeff Reeves Technical Sales Representative (270) 619-0987	Mike Lauderdale Technical Sales Representative (205) 913- 0465	ELKO, NV Troy Timothy Technical Sales Representative Hard Rock Division (775) 299-9299
Jimmy Hull Regional Sales Manager – Eastern Region (304) 312-953	Jamey Lutz Technical Sales Representative Special Projects (270) 339-9121	Denny Barton Technical Sales Representative (276) 701-0180	Tommie Breeden Technical Sales Representative (970) 261-5883
Kevin Ewusiak Technical Sales Representative (304) 559-2000	Ray Wilson Regional Sales Manager – Midwest (205) 790-4259	Tony Brown Inside Sales (423) 341-5362	Brady Weekly Technical Sales Representative Hard Rock Division (412) 925-0876
Caleb Barley Technical Sales Representative (304) 575-2011	Tabitha Hill Inventory Manager/ Sales Representative (207) 836-6539	CLEARFIELD TOOLE, UT Kevin Poulson Technical Sales Representative (435) 851-3114	Scott Kafton Technical Sales Representative (775) 340-0739
		James Avery Technical Sales Representative (970) 261-8647	

AFFILIATES

JENNCHEM EASTERN REGION Drew Morgan Regional Sales Manager (517) 936-9356	WEST Steve West Regional Sales Manager (970) 275-3950	William “Billy” Sawyers Project Engineer (276) 971-7036	Christopher Simpson Project Manager (304) 685-7260
Adam Duitl Technical Sales Representative (802) 238-4029	SOUTH David Gable Regional Sales Manager (205) 999-4577	JM STEEL Kyle Lonneman Vice President of Sales (843) 297-6370	XCAL TOOLS Bruce Johnson Vice President (724) 448-1955
MID-WEST REGION Cody Lafever Regional Sales Manager (412) 713-9561	CIVIL Jacob Hunter JM Civil Manager (740) 508-2316	Matthew Brock Vice President/ General Manager (843) 810-8803	Brian McGillis Global Sales Manager (705) 665-3274
APPALACHIA Duke Gray Regional Sales Manager (423) 534-4319	Ashley Tedesco Business Manager (412) 963-5426	CONVEYORS Brent McClain Vice President (724) 416-3618	

Table of Contents

LOCATIONS	3
SALES CONTACTS	4
CAP CARBIDE TIPS	6
TOOL WEAR & CHARACTERISTICS	7-8
TOOL RECOMMENDATION	9-10
CEMENTED CARBIDE	11
SYSTEM 2000	20

ROAD MILLING/RECLAIMING

JMXR-668	14
JMXR-XTEND-68	14
JMXR-779	14
JMXR-727HD	14
JMXR-529	14
JMXR-779HD	14
JMXR-786HD	14
JMXR-526	14
JMXR-684	14
JMXR-XTEND-84	14
JMXR-727	15
JMXR-425	15
JMXR-2229	15
JMXR-2203	15
JMXR-22XX	15
JMXR-XTEND-27HD	15
JMXR-668HD	15
JMXR-614	15
JMXB-22H	17
JMXB-19S	16
JMXB-22T	17
JMXB-19H	16
JMXB-19L	16
JMXA-FP19	18
JMXA-CKP	18
JMXA-AH38	18
JMXA-FP22	18
JMXA-AH12	18

GRADING

JMXG-2228W	22
JMXG-2270W	22
JMXG-2228	22
JMXG-2523W	22
JMXG-2513W	22
JMXG-3520W	22
JMXG-2227	22
JMXG-2201	22

DRILLING

JMXD-1901FSR	25
JMXD-2201FSR	25
JMXD-3820SR	25
JMXD-3820SR	25
JMXD-3821DR	25
JMXD-3821SR	25
JMXB-19H	26
JMXB-19S	26
JMXB-38H	26
JMXB-38HV	27
JMXB-38HSS	27
JMXB-38HST	27

TRENCHING

JMXT-2201BFS	30
JMXT-2501BGR	30
JMXT-2535BGR	30
JMXT-2542BGR	30
JMXT-1801BGR	30
JMXT-1901BGR	30
JMXT-2523CC	31
JMXT-2574CC	31
JMXT-3874CC	31
JMXB-19S	32
JMXB-19H	32
JMXB-22H	32
JMXB-22N	33
JMXB-25HS	33
JMXB-38H	33
JMXB-38HSS	34
JMXB-38HST	34
JMXB-38HV	34
JMXA-FP25	35
JMXA-FP19	35
JMXA-CKP	35
JMXA-AH38	35
JMXA-FP22	36
JMXA-CC30	36
JMXA-AH12	36
JMXA-CC25	36

PART NUMBER REFERENCE GUIDE	37-38
-----------------------------------	-------

Carbide Tips

We offer a wide range of carbide tips to match the various challenges that you might face. All of our tips provide superb penetration and maximum productivity – regardless of whether you work in soft, medium-hard or really hard and demanding conditions.





Tool Wear

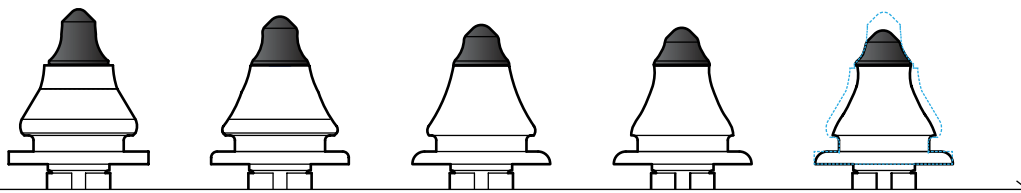

Standard Body - Wear Over Time*

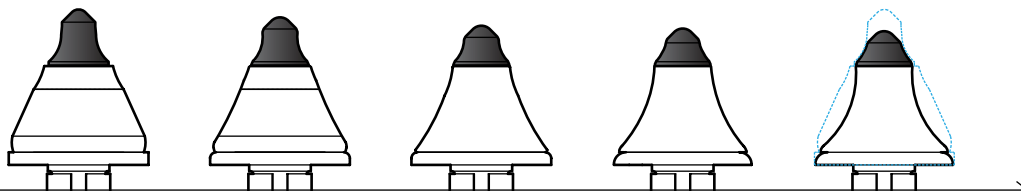

Heavy Duty Body - Wear Over Time*

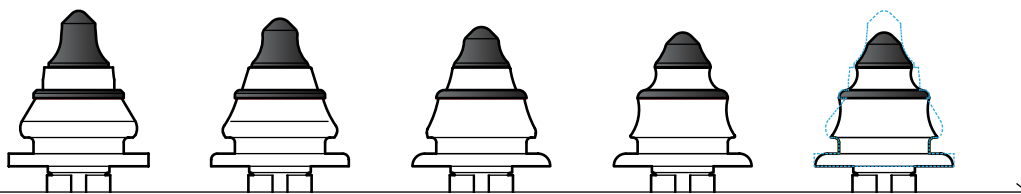

Xtend-A-Bit Body - Wear Over Time*

Extended Use and Optimized Safety

Xtend-A-Bit tools are equipped with a carbide ring placed slightly below the tip to prevent body wear and maximize carbide tip use. Each tool is available with either a valve seat or CAP carbide tip. Xtend-A-Bit tools reign supreme in high body wash conditions.

Tool Wear Characteristics

For maximum productivity, use tools until stage three of wear.

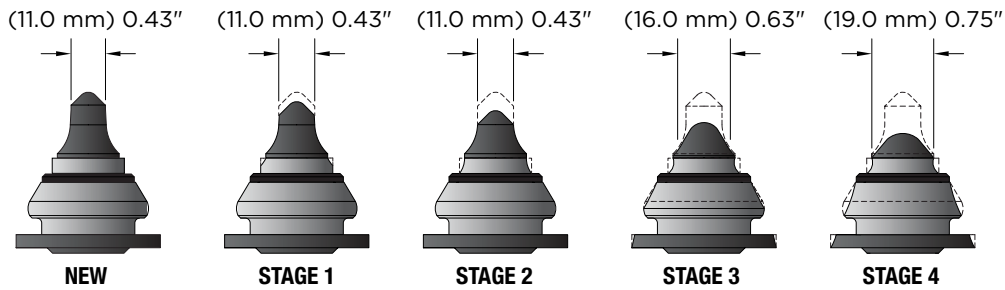

Tools Engaged and Surface Area of the Tip in the Cut

This chart shows the change in the total surface area of tips engaged as wear occurs. Tip wear relates to the depth of cut and speed at which the machine is operating, as indicated below.

SPEED				NP68 SURFACE AREA OF TIPS IN THE CUT										
				NEW TOOL		STAGE 1		STAGE 2		STAGE 3		STAGE 4		
				cm ²	in ²	cm ²	in ²	cm ²	in ²	cm ²	in ²	cm ²	in ²	
DEPTH OF CUT	MPM	FPM	TOOLS ENGAGED *	1.00	.15	1.00	.15	1.00	.15	2.00	.322	.8	0.43	
(3.8 cm)	1.5"	9.1	30	11	10.5	1.62	10.5	1.62	10.5	1.62	22.4	3.47	30.9	4.78
(3.8 cm)	1.5"	18.3	60	13	12.4	1.91	12.4	1.91	12.4	1.91	26.5	4.10	36.5	5.65
(3.8 cm)	1.5"	36.6	120	17	16.2	2.50	16.2	2.50	16.2	2.50	34.6	5.37	47.7	7.39
(7.6 cm)	3"	9.1	30	15	14.3	2.21	14.3	2.21	14.3	2.21	30.6	4.47	42.1	6.52
(7.6 cm)	3"	18.3	60	16	15.2	2.36	15.2	2.36	15.2	2.36	32.6	5.05	44.9	6.96
(7.6 cm)	3"	36.6	120	20	19.0	2.95	19.0	2.95	19.0	2.95	40.7	6.31	56.1	8.69
(15.2 cm)	6"	9.1	30	20	19.0	2.95	19.0	2.95	19.0	2.95	40.7	6.31	56.1	8.69
(15.2 cm)	6"	18.3	60	22	20.9	3.24	20.9	3.24	20.9	3.24	44.8	6.95	61.7	9.56
(15.2 cm)	6"	36.6	120	26	24.7	3.83	24.7	3.83	24.7	3.83	53.0	8.21	72.9	11.30
(30.5 cm)	12"	9.1	30	28	26.6	4.12	26.6	4.12	26.6	4.12	57.0	8.84	78.5	12.17
(30.5 cm)	12"	18.3	60	30	28.5	4.42	28.5	4.42	28.5	4.42	61.1	9.47	84.1	13.04





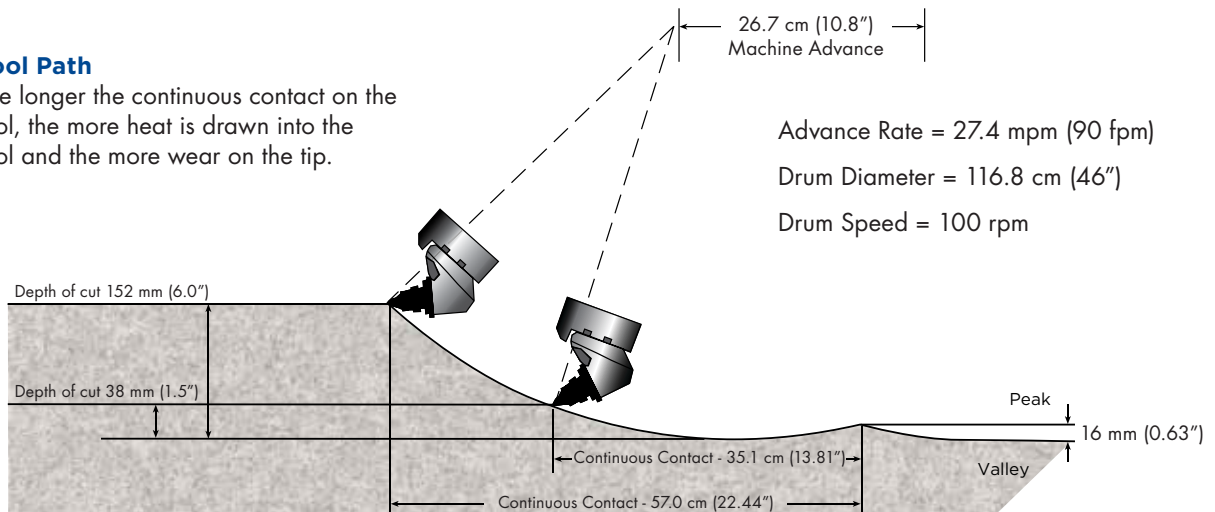







Tool Path

The longer the continuous contact on the tool, the more heat is drawn into the tool and the more wear on the tip.











Tool Recommendation

Use this chart to educate and familiarize yourself with our tool types and numbering system, along with appropriate applications, conditions and power requirements.

TOOL PROFILE	PART NUMBER	MATERIAL				DEPTH OF CUT			MACHINE HP			TIP TYPE	BODY TYPE		PULLER GROOVE	PAGE
		ASPHALT	CONCRETE	ABRASIVE	RECLAIMING	SHALLOW (<50 MM)	MEDIUM (50-250 MM)	DEEP (250 MM+)	>200 HP	200-500 HP	500 HP+		STANDARD	HEAVY DUTY		
	19 MM - EXTEND-A-BIT															
	JMXR-XTEND-68	✓		✓			✓	✓		✓	✓	 CAP NP68	✓		✓	15
	JMXR-XTEND-84	✓		✓			✓	✓		✓	✓	 CAP NP84	✓		✓	15
	JMXR-XTEND-27HD	✓		✓	✓		✓	✓		✓	✓	 VALVE NP27		✓		16
	19 MM - HEAVY DUTY BODY															
	JMXR-727HD	✓	✓	✓	✓		✓	✓		✓	✓	 VALVE NP27		✓		15
	JMXR-668HD	✓		✓			✓	✓		✓	✓	 CAP NP68		✓		16
	JMXR-779HD	✓		✓			✓	✓		✓	✓	 CAP NP79		✓		15
	JMXR-786HD	✓		✓	✓		✓	✓		✓	✓	 VALVE NP86		✓		15
	JMXR-614		✓			✓	✓	✓	✓	✓	✓	 INSERT NP14	✓		✓	16
	22 MM															
	JMXR-2203		✓			✓	✓	✓	✓	✓	✓	 INSERT NP03	✓		✓	16
	JMXR-2229	✓				✓	✓		✓			 CAP NP29	✓		✓	16

Tool Recommendation

Use this chart to educate and familiarize yourself with our tool types and numbering system, along with appropriate applications, conditions and power requirements.

TOOL PROFILE	PART NUMBER	MATERIAL				DEPTH OF CUT			MACHINE HP			TIP TYPE	BODY TYPE		PULLER GROOVE	PAGE
		ASPHALT	CONCRETE	ABRASIVE	RECLAIMING	SHALLOW (<50 MM)	MEDIUM (50-250 MM)	DEEP (250 MM+)	>200 HP	200-500 HP	500 HP+		STANDARD	HEAVY DUTY		
	19 MM - STANDARD BODY															
	JMXR-425	✓				✓	✓		✓			 CAP NP25	✓		✓	16
	JMXR-526	✓				✓	✓		✓			 CAP NP26	✓		✓	15
	JMXR-727	✓	✓				✓	✓		✓	✓	 VALVE NP27	✓		✓	16
	JMXR-529	✓				✓	✓		✓			 CAP NP29	✓		✓	15
	JMXR-668	✓				✓	✓	✓	✓	✓	✓	 CAP NP68	✓		✓	15
	JMXR-779	✓					✓	✓		✓	✓	 CAP NP79	✓		✓	15
	JMXR-684	✓					✓	✓		✓	✓	 CAP NP84	✓		✓	15

Cemented Carbide

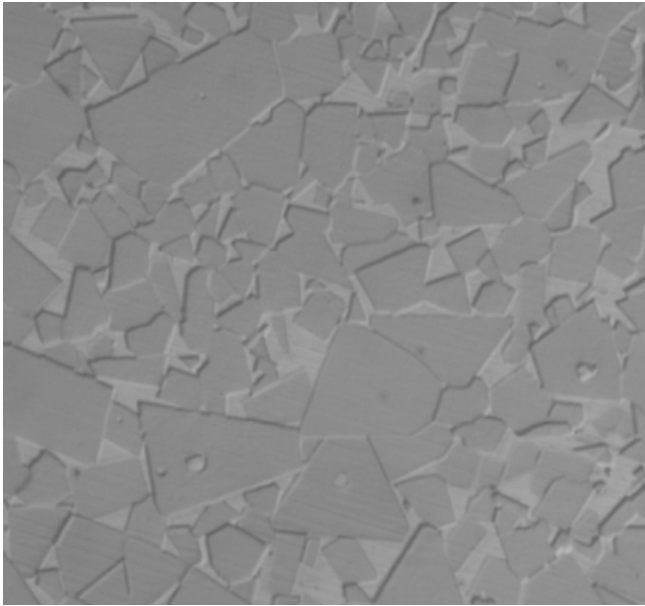

Figure 1
Mining Grade TC95 (1500X)

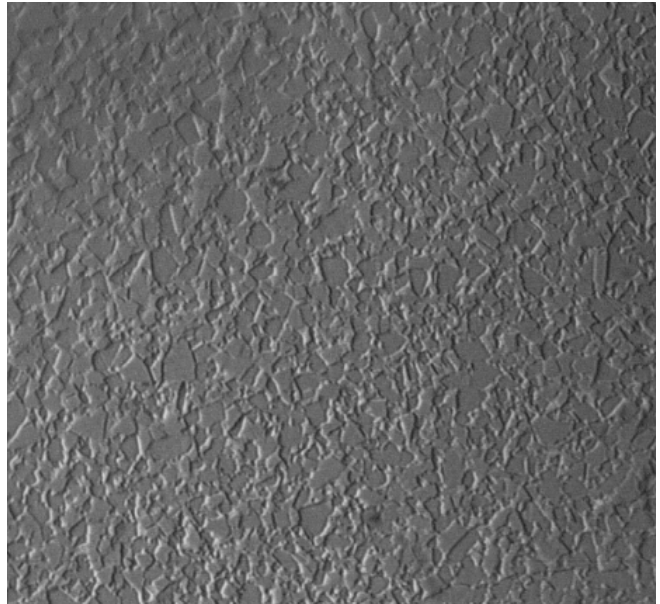

Figure 2
Roof Drilling Grade TM6 (1500X)

For over 20 years, we have been producing high quality carbide for the mining, roof drilling, snow and ice removal, road planing, wear products and metal cutting blanks. We are an ISO 9001 certified facility. Producing over fifty grades of cemented carbide and the ability to create new ones, we can find a carbide grade to meet your needs. We have been a leader in mining and roof drilling grades as the formations have shifted from softer to harder conditions. We have developed extra coarse tougher grades to meet this demand. Our TC95 (mining) and TM6 (roof drilling) are industry leaders. We check the quality of the carbide grades at each step which assures the powder has uniform grain structure and distribution and finished parts meet critical property specifications. Our flexibility allows us to quickly test and adapt to changing environments and customer needs. Our cost effective production methods, allow us to provide a competitive product of the highest quality.



ROAD MILLING & RECLAIMING

Road Milling/Reclaiming

Features:

- Unique tool design provides superior rotation
- Full sleeve retainer and washer maintain maximum block bore and seat protection
- Improved thicker washer for increased protection and longer life
- Puller groove for easy extraction

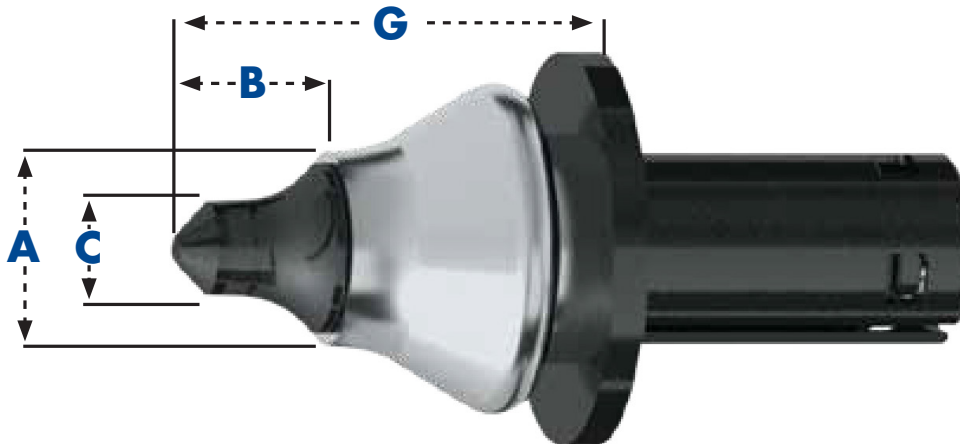

G - Gauge

A - Base Diameter

B - Tip Height

C - Tip Diameter

Valve Seat Carbide Tips

Valve seat carbide are preferred in tough milling or reclaiming applications.

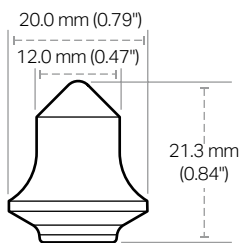

NP27

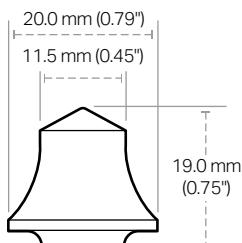

NP86

Cap Carbide Tips

Flat bottom cap carbide tips are the preferred general application tip that effectively works in 80% of cutting conditions.

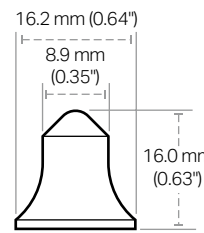

NP25

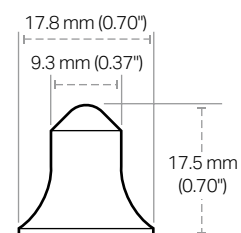

NP26

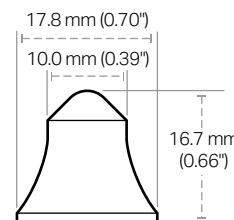

NP29

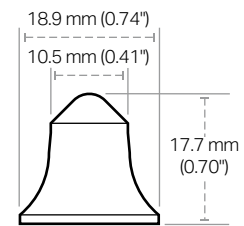

NP68

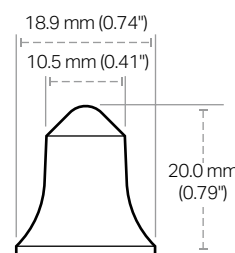



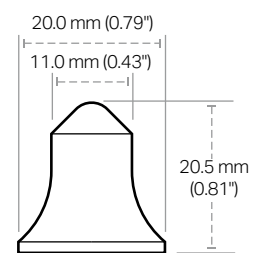

NP84

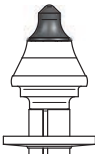
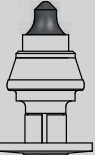

NP79

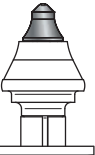
Road Milling/Reclaiming

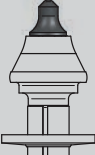
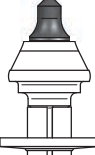
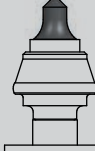
	Part Number Product Code	G - Gauge (mm, in)	A - Base Diameter (mm, in)	B - Tip Height (mm, in)	C - Tip Diameter (mm, in)	Pieces per Box	Boxes per Pallet	Pieces per Pallet
	JM XR-668	49.0 mm 1.92 in	19.1 mm 0.75 in	17.5 mm 0.69 in	10.5 mm 0.41 in	50	60	3000
	JM XR-XTEND-68	49.0 mm 1.77 in	19.1 mm 0.75 in	17.5 mm 0.69 in	10.5 mm 0.41 in	50	60	3000
	JM XR-779	48.0 mm 1.88 in	20.1 mm 0.80 in	20.4 mm 0.80 in	11.0 mm 0.43 in	50	60	3000
	JM XR-727HD	48.0 mm 1.88 in	20.2 mm 0.79 in	21.6 mm 0.85 in	11.9 mm 0.47 in	50	60	3000
	JM XR-529	48.0 mm 1.89 in	17.9 mm 0.70 in	16.8 mm 0.66 in	10.1 mm 0.40 in	50	60	3000
	JM XR-779HD	48.0 mm 1.90 in	20.0 mm 0.78 in	20.4 mm 0.80 in	10.9 mm 0.43 in	50	60	3000
	JM XR-786HD	47.0 mm 1.83 in	20.2 mm 0.79 in	18.9 mm 0.74 in	11.4 mm 0.45 in	50	60	3000
	JM XR-526	49.0 mm 1.92 in	17.9 mm 0.70 in	17.3 mm 0.68 in	9.2 mm 0.36 in	50	60	3000
	JM XR-684	47.0 mm 1.86 in	19.1 mm 0.75 in	19.9 mm 0.78 in	10.5 mm 0.41 in	50	60	3000
	JM XR-XTEND-84	47.0 mm 1.86 in	19.1 mm 0.75 in	19.9 mm 0.78 in	10.5 mm 0.41 in	50	60	3000

Road Milling/Reclaiming

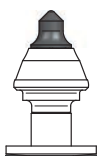
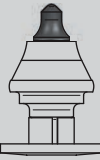
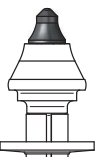
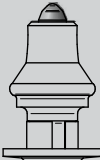
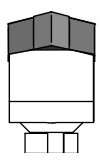
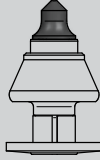
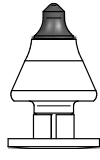
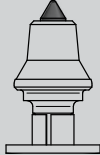
	Part Number Product Code	G - Gauge (mm, in)	A - Base Diameter (mm, in)	B - Tip Height (mm, in)	C - Tip Diameter (mm, in)	Pieces per Box	Boxes per Pallet	Pieces per Pallet
	JMXR-727	49.0 mm 1.91 in	20.2 mm 0.79 in	21.3 mm 0.84 in	12.0 mm 0.47 in	50	60	3000
	JMXR-425	47.0 mm 1.86 in	16.2 mm 0.63 in	16.0 mm 0.63 in	8.9 mm 0.35 in	50	60	3000
	JMXR-2229	48.0 mm 1.89 in	17.9 mm 0.70 in	16.8 mm 0.66 in	10.1 mm 0.40 in	50	60	3000
	JMXR-2203	49.0 mm 1.93 in	12.1 mm 0.48 in	21.4 mm 0.84 in	12.1 mm 0.47 in	50	60	3000
	JMXR-22XX	50 mm 2.00 in	NA	NA	NA	40	60	2400
	JMXR-XTEND-27HD	47.0 mm 1.86 in	20.2 mm 0.79 in	21.2 mm 0.83 in	12.0 mm 0.47 in	50	60	3000
	JMXR-668HD	49.0 mm 1.92 in	19.1 mm 0.75 in	17.5 mm 0.69 in	10.5 mm 0.41 in	50	60	3000
	JMXR-614	52.0 mm 2.04 in	12.1 mm 0.48 in	21.4 mm 0.84 in	12.1 mm 0.47 in	50	60	3000

Blocks

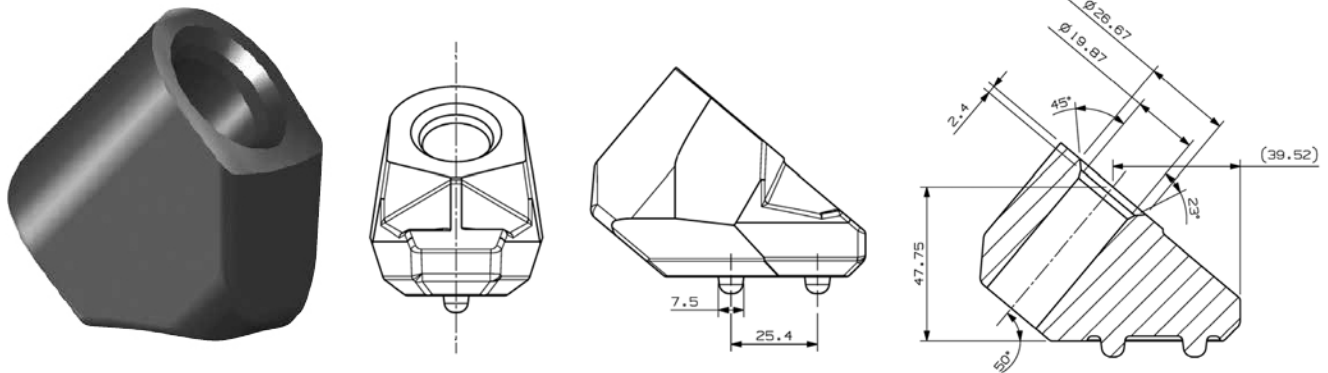

Standard Block

Part Number/Product Code	Bore Hole Dimension	Pieces per Box	Boxes per Pallet	Pieces per Pallet
JMXB-19S	19mm - straight bore	35	60	2100

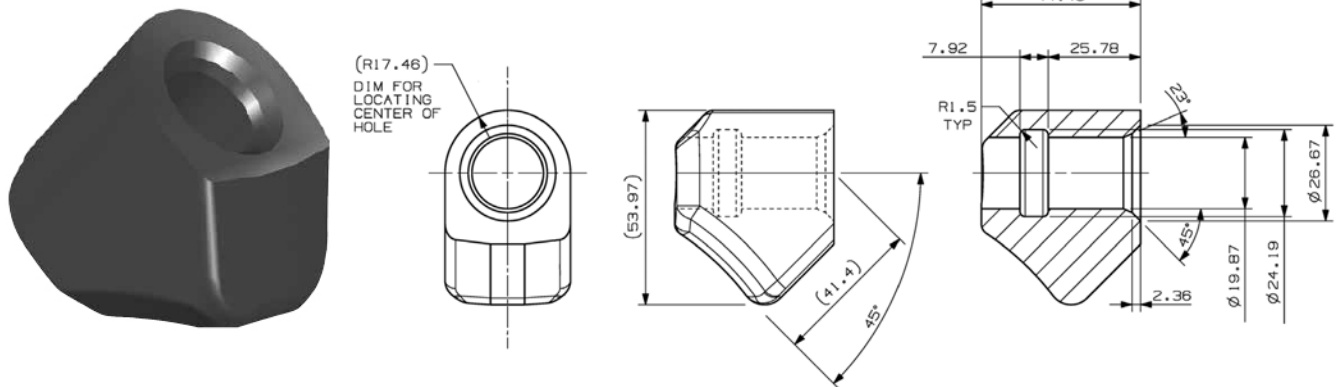

Heavy Duty Block

Part Number/Product Code	Bore Hole Dimension	Pieces per Box	Boxes per Pallet	Pieces per Pallet
JMXB-19H	19mm - straight bore	35	60	2100

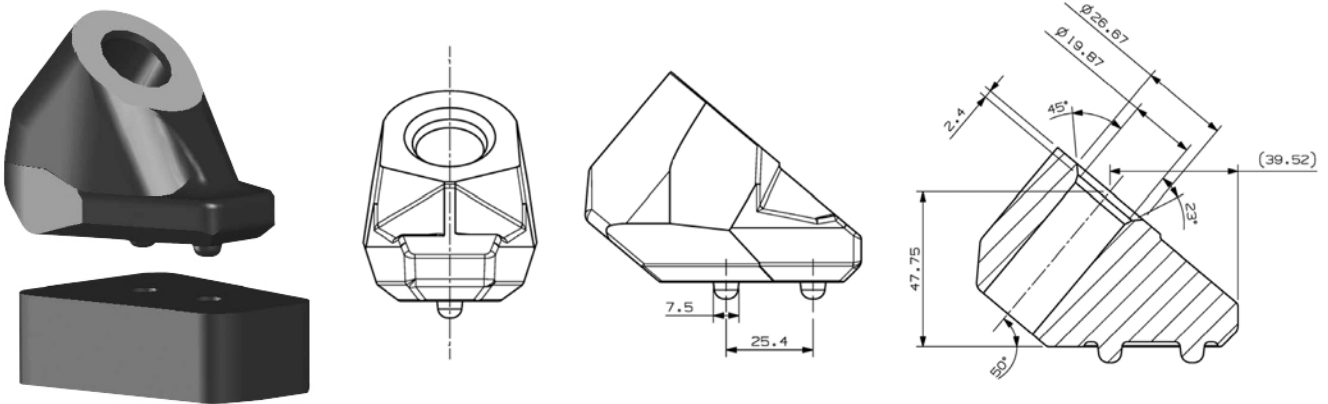

Block features locator pins for easy alignment. The "V"-shaped front reduces wear by channeling material away from the face. Use M8D-0003 base with JMXB-19L block

Part Number/Product Code	Bore Hole Dimension	Pieces per Box	Boxes per Pallet	Pieces per Pallet
JMXB-19L	19mm - straight bore	15	60	900

Blocks

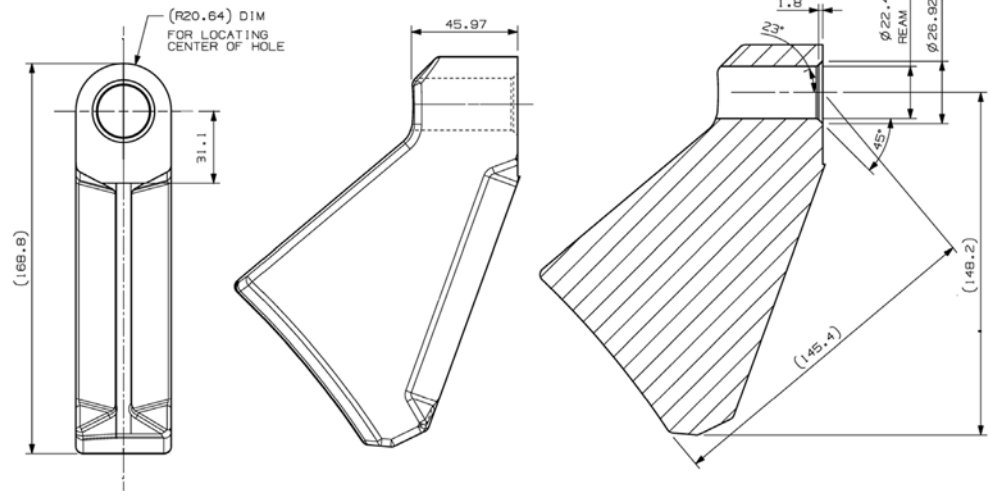

Block is 2 inches (51 mm) taller than B4A22 and is ideal for use on 34-inch-diameter (864 mm) drums on reclaimers

Part Number/Product Code	Bore Hole Dimension	Pieces per Box	Boxes per Pallet	Pieces per Pallet
JMXB-22T	22mm - straight bore	6	60	360

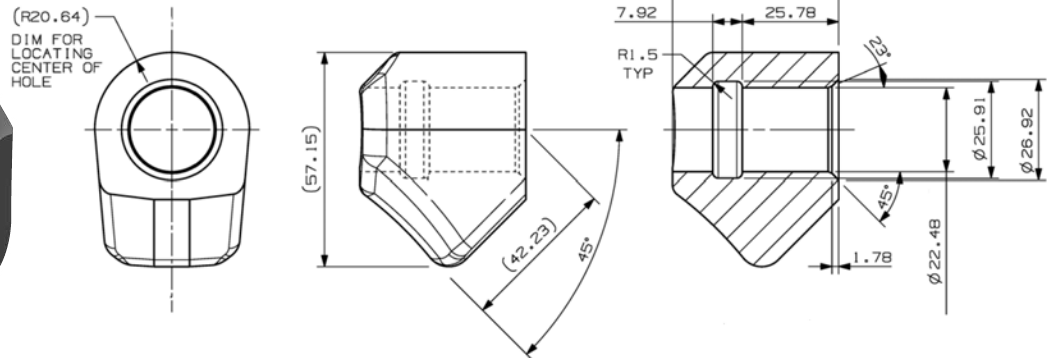
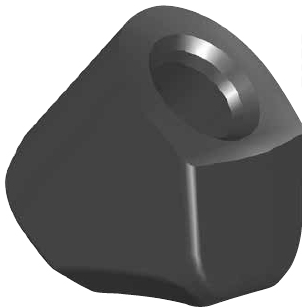

Heavy Duty Block

Part Number/Product Code	Bore Hole Dimension	Pieces per Box	Boxes per Pallet	Pieces per Pallet
JMXB-22H	22mm - straight bore	35	60	2100

Accessories

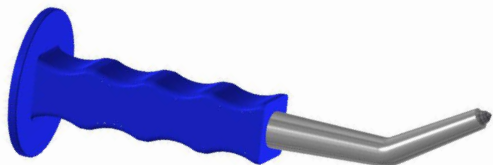

CURVED KNOCK OUT PUNCH - Tool remover with carbide tip for extended life.

Part Number

Product Code

JMXA-CKP



FORKED PULLER - For removal of tools with 19mm shank

Part Number

Product Code

JMXA-FP19



FORKED PULLER - For removal of tools with 22mm shank

Part Number

Product Code

JMXA-FP22



AIR HAMMER PUNCH - 3/8" chuck.

Part Number

Product Code

JMXA-AH38

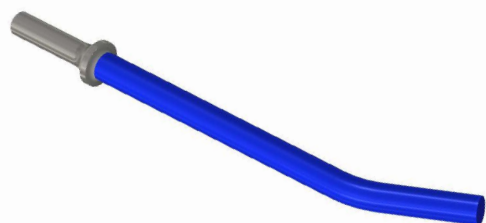

AIR HAMMER PUNCH - 1/2" chuck.

Part Number

Product Code

JMXB-AH12



GRADING SYSTEMS

System 2000

The System 2000 is an innovative road grading system that uses rotating, replaceable tungsten carbide tools as a cutting edge, ideal for maintaining a variety of non-hard surfaced roads (e.g., ice, dirt, gravel, hauling roads, roads including public road districts, private construction contractors, federal land management, logging and mining roads). It works by utilizing a replaceable conical tool installed in a heat-treated adaptor board that allows better wear resistance and improved cutting capability over conventional steel blades and can be mounted on a motor grader in place of a conventional blade. It can also be mounted to an under body blade on a truck or a rear blade on a tractor.

Features and Benefits:

- **Lower Grading Costs:** Reduced equipment costs with a blade life equal to 5 to 15 sets of conventional blades.
- **Negligible Downtime:** Easy handling and installation in the field with no heavy lift required.
- **Improves Road Surface:** Cuts road surface instead of scraping providing improved mix of materials.
- **Increases Productivity:** Reduces dust and brings larger gravel particles to top of road surface.
- **Cost Effective Asphalt Removal:** Easily removes asphalt to desired profile and granulates material to a uniform size to be re-used for fill.
- **Excellent Ice Removal System:** Cutting action produces a grooved surface providing improved road traction.

Applications:

- Gravel reclamation and maintenance.
- Oil road reclamation.
- Asphalt planing or following a milling machine to remove final layer of asphalt.
- Removal of potholes and washboards on dirt or gravel roads.
- Removal of temporary pavement marking.
- Ice and snow removal.

System 2000 Square Washers

In addition to the integral end protector – which always leaves cutting edges straight – the latest innovation to the System 2000 is a unique patent-pending square washer that further increases productivity.

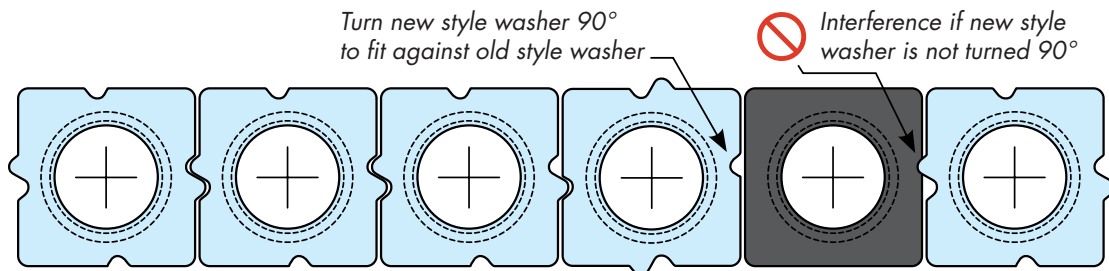
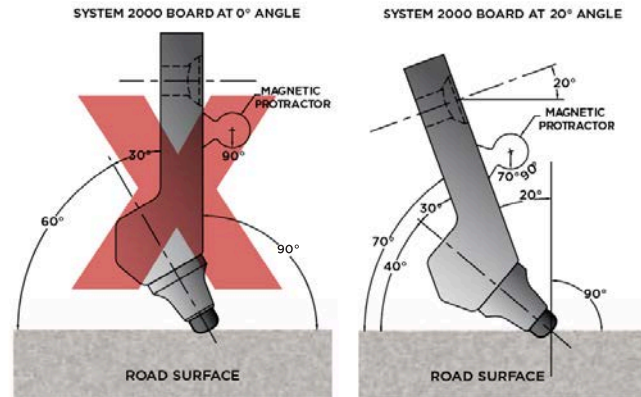

System 2000 Square Washers With Interlocking Feature (For 22 mm And 25 mm Tools) *Patent-Protected Square Washer

Square Washer Benefits:

- New “gear tooth” arrangement prevents washers from sliding and opening a gap between the tools.
- Compatible with old-style square washer and end protectors.
- Pre-compressed retainer for easy installation.
- Enhances tool rotation.
- Eliminates washer rotation, preventing wear between washer and mating surface.
- Provides support and stability to the tool with an extruded cone that fits neatly into the bore of the adaptor board.
- Serves as a replaceable “armor plate” wear surface.

Grading

Features:

- “Gear Tooth” washer protects board mating face
- Retainer compressed for easy installation
- Multiple tip options for different applications

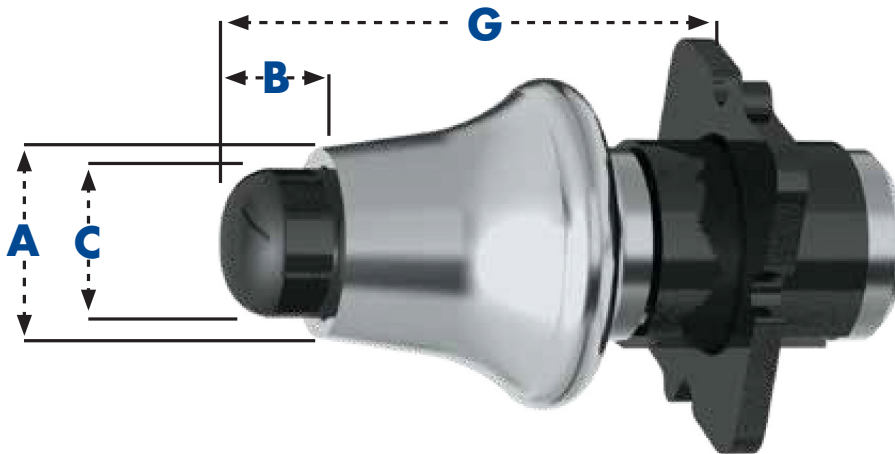

G - Gauge

A - Base Diameter

B - Tip Height

C - Tip Diameter

Insert Carbide Tips

Insert carbide tips are best suited for penetration applications where steel wash is not an issue. These tips are ideal for use in hard, high-impact conditions. Available only on 25mm tools only.

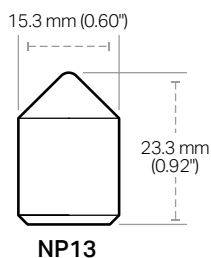



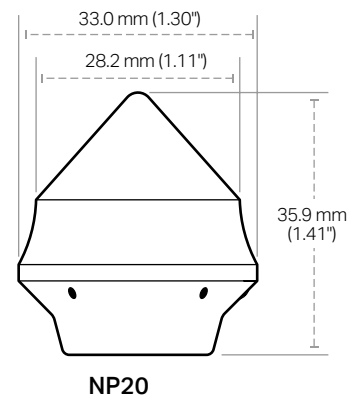
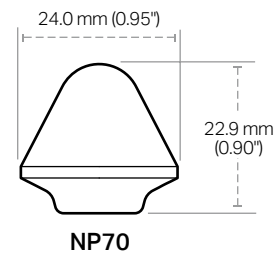
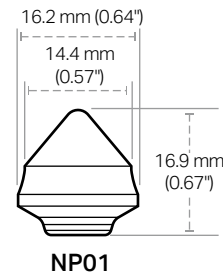
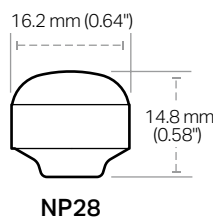
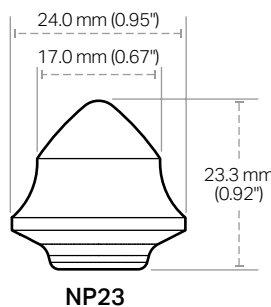

Valve Seat Carbide Tips

Valve seat carbide are preferred in tough milling or reclaiming applications.

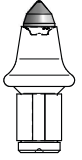

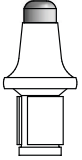
Grading

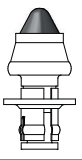
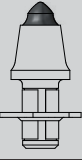
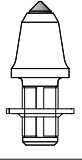
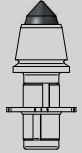
	Part Number Product Code	G - Gauge (mm, in)	A - Base Diameter (mm, in)	B - Tip Height (mm, in)	C - Tip Diameter (mm, in)	Pieces per Box	Boxes per Pallet	Pieces per Pallet
	JMXG-2201	44.0 mm 1.73 in	16.0 mm 0.60 in	17.4 mm 0.58 in	12.8 mm 1.11 in	65	60	3900
	JMXG-2227	40.0 mm 1.57 in	20.2 mm 0.94 in	21.2 mm 0.58 in	11.9 mm 1.11 in	65	60	3900
	JMXG-2228	42.0 mm 1.65 in	16.2 mm 0.64 in	14.8 mm 0.58 in	16.2 mm 0.64 in	65	60	3900
	JMXG-2228W	43.0 mm 1.70 in	16.2 mm 0.64 in	14.8 mm 0.58 in	16.2 mm 0.64 in	50	60	3000
	JMXG-2270W	43.0 mm 1.70 in	24.0 mm 0.94 in	22.8 mm 0.89 in	N/A	40	60	2400
	JMXG-2523W	57.0 mm 2.23 in	24.7 mm 0.97 in	23.8 mm 0.93 in	17.3 mm 0.68 in	30	60	1800
	JMXG-2513W	57.0 mm 2.24 in	15.3 mm 0.60 in	23.0 mm 0.90 in	15.3 mm 0.60 in	30	60	1800
	JMXG-3520W	74.0 mm 2.91 in	33.0 mm 1.29 in	35.6 mm 1.40 in	28.2 mm 1.11 in	8	60	480



DRILLING

Drilling

Features:

- Internal retainer compressed for easy installation or external retainer (c-clip or snapping)
- Multiple tip options for different applications

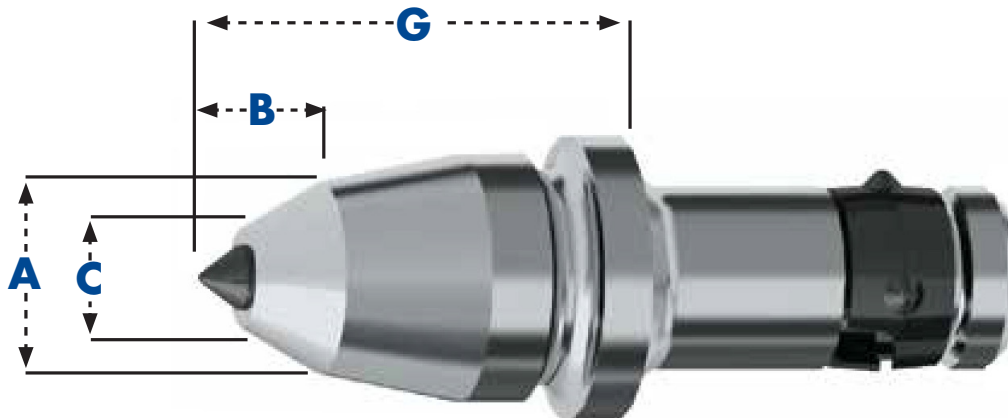

G - Gauge

A - Base Diameter

B - Tip Height

C - Tip Diameter

Insert Carbide Tips

Insert carbide tips are best suited for penetration applications where steel wash is not an issue. These tips are ideal for use in hard, high-impact conditions. Available only on 25mm tools only.

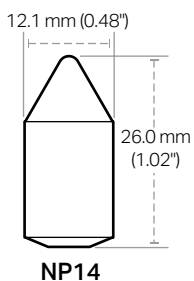
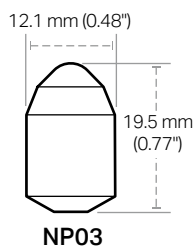
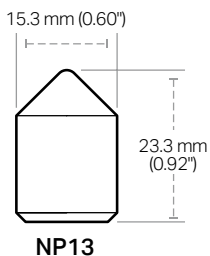





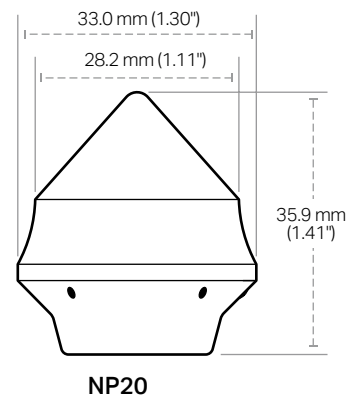
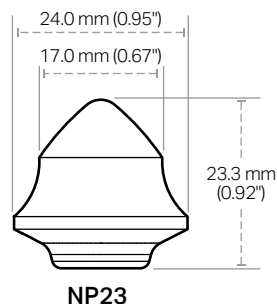
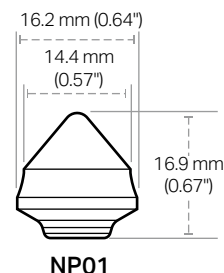

Valve Seat Carbide Tips

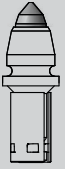
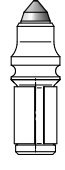
Valve seat carbide are preferred in tough milling or reclaiming applications.

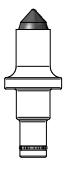

Drilling

	Part Number Product Code	G - Gauge (mm, in)	A - Base Diameter (mm, in)	B - Tip Height (mm, in)	C - Tip Diameter (mm, in)	Pieces per Box	Boxes per Pallet	Pieces per Pallet
	19 MM							
	JMXD-1901FSR	44.4 mm 1.74 in	16.2 mm 0.64 in	17.4 mm 0.68 in	12.8 mm 0.50 in	60	60	3600
	22 MM							
	JMXD-2201FSR	44.0 mm 1.73 in	16.2 mm 0.64 in	17.4 mm 0.68 in	12.8 mm 0.50 in	50	60	3000
	38/30 MM							
	JMXD-3820XR	64.0 mm 2.51 in	33.0 mm 1.29 in	35.6 mm 1.40 in	28.2 mm 1.11 in	10	60	400
	JMXD-3820SR	89.0 mm 3.50 in	33.0 mm 1.29 in	35.6 mm 1.40 in	28.2 mm 1.11 in	10	60	400
	JMXD-3808SR	123.1 mm 4.85 in	18.0 mm 0.71 in	22.3 mm 0.88 in	18.0 mm 0.70 in	15	60	600
	JMXD-3821SR	123.1 mm 4.85 in	18.0 mm 0.71 in	28.8 mm 1.13 in	18.0 mm 0.70 in	15	60	600
	JMXD-3821DR	90.0 mm 3.54 in	18.0 mm 0.71 in	28.8 mm 1.13 in	18.0 mm 0.70 in	10	60	600

Blocks

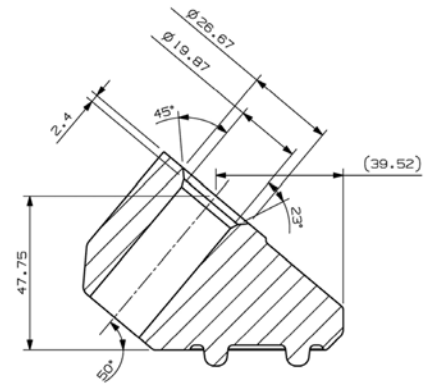
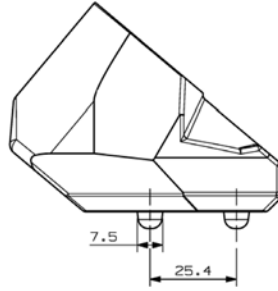
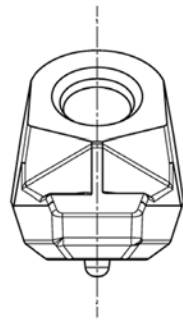

Standard Block

Part Number/Product Code	Bore Hole Dimension	Pieces per Box	Boxes per Pallet	Pieces per Pallet
JMxB-19S	19mm - straight bore	35	60	2100

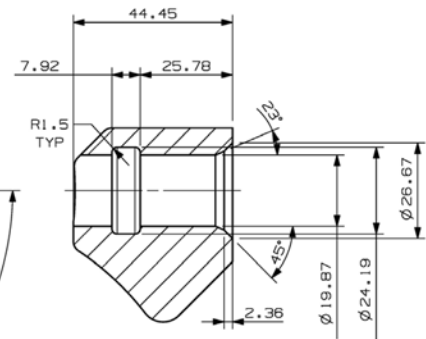
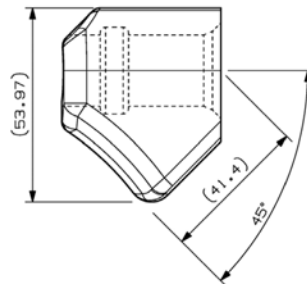
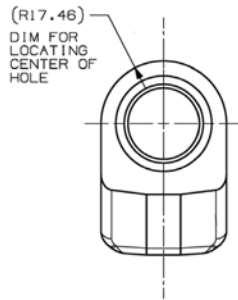
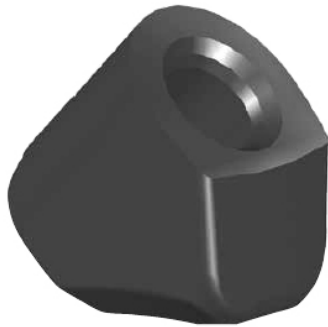

Heavy Duty Block

Part Number/Product Code	Bore Hole Dimension	Pieces per Box	Boxes per Pallet	Pieces per Pallet
JMxB-19H	19mm - straight bore	35	60	2100

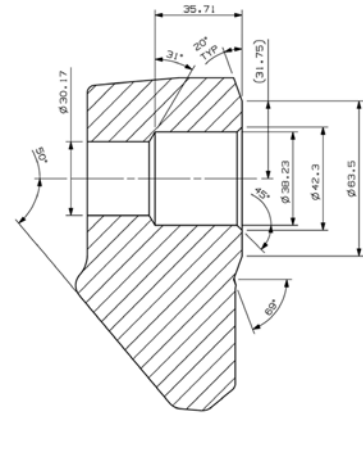
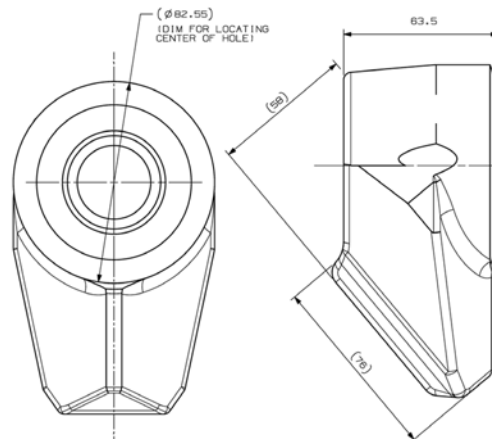

A heavy-duty block that features a "V" design, which provides greater surface-weld area

Part Number/Product Code	Bore Hole Dimension	Pieces per Box	Boxes per Pallet	Pieces per Pallet
JMxB-38H	30/38mm - stepped bore	8	60	480

Blocks

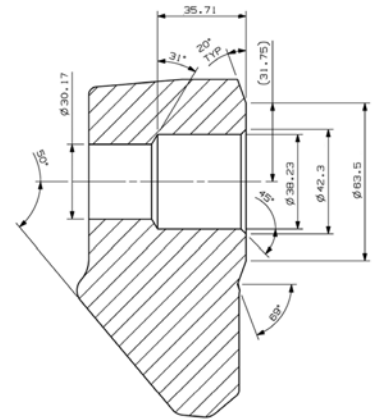
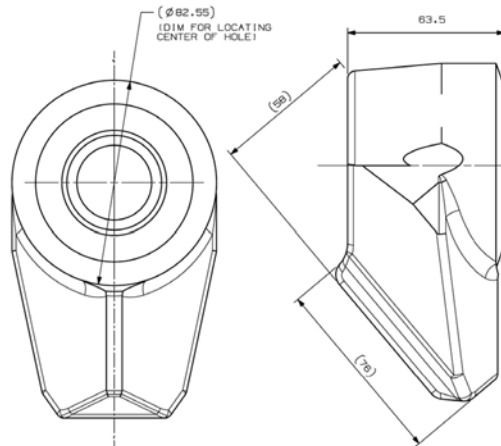

A heavy-duty block that features a "V" design, which provides greater surface-weld area

Part Number/Product Code	Bore Hole Dimension	Pieces per Box	Boxes per Pallet	Pieces per Pallet
JMXB-38HV	30/38mm - stepped bore	6	60	360

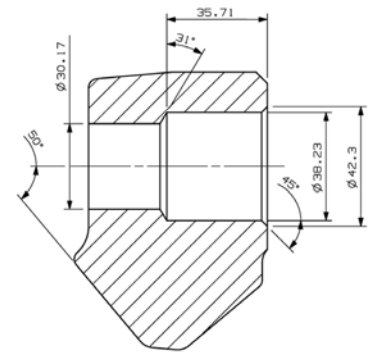
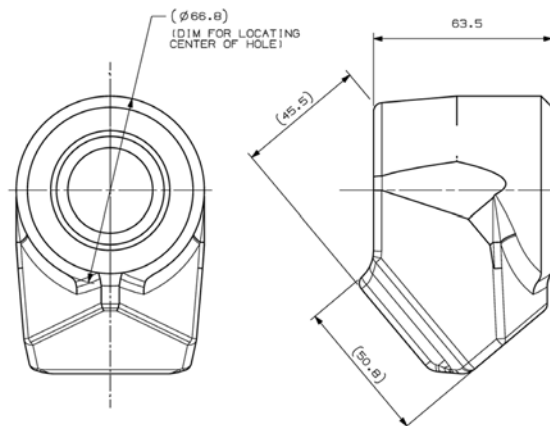

A heavy-duty block with shorter base for compact positioning

Part Number/Product Code	Bore Hole Dimension	Pieces per Box	Boxes per Pallet	Pieces per Pallet
JMXB-38HSS	30/38mm - stepped bore	6	60	360

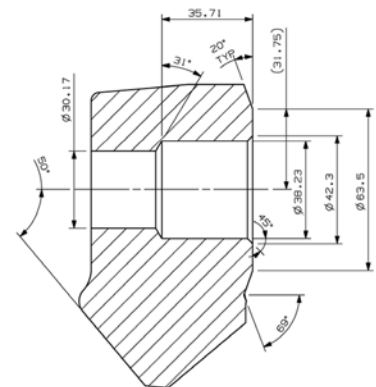
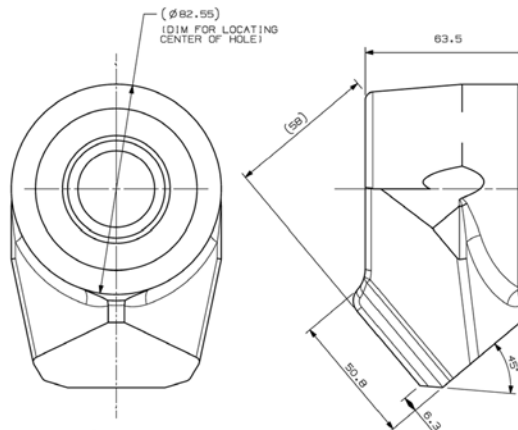

A heavy-duty block with shorter base for compact positioning

Part Number/Product Code	Bore Hole Dimension	Pieces per Box	Boxes per Pallet	Pieces per Pallet
JMXB-38HST	30/38mm - stepped bore	6	60	360

Accessories

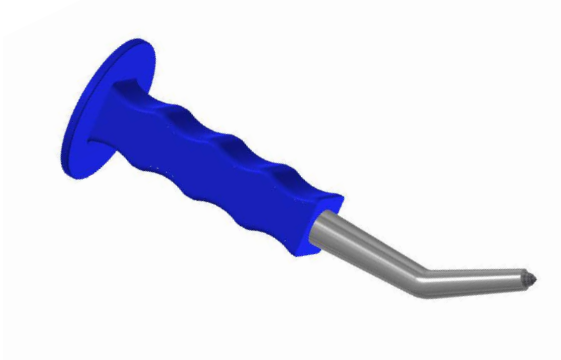

CURVED KNOCK OUT PUNCH - Tool remover with carbide tip for extended life.

Part Number
Product Code

JMXA-CKP



FORKED PULLER - For removal of tools with 19mm shank

Part Number
Product Code

JMXA-FP19



FORKED PULLER - For removal of tools with 22mm shank

Part Number
Product Code

JMXA-FP22

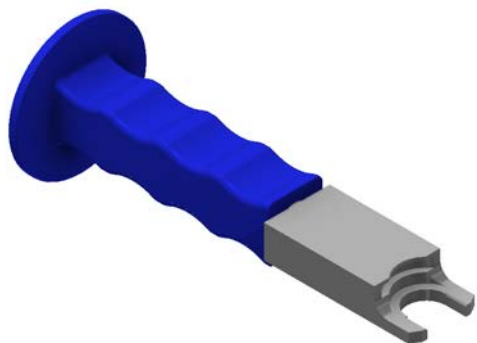

INSTALLATION/REMOVAL - For removal of c-clip 30mm shank.







Part Number
Product Code

JMXB-CC30

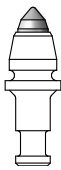



TRENCHING

Trenching

	Part Number Product Code	G - Gauge (mm, in)	A - Base Diameter (mm, in)	B - Tip Height (mm, in)	C - Tip Diameter (mm, in)	Pieces per Box	Boxes per Pallet	Pieces per Pallet
	18 MM							
	JMXT-1801BGR	44.0 mm 1.73 in	16.2 mm 0.64 in	17.4 mm 0.68 in	12.8 mm 0.50 in	65	60	3900
	19 MM							
	JMXT-1901BGR	43.0 mm 1.69 in	16.2 mm 0.64 in	17.4 mm 0.68 in	12.8 mm 0.50 in	65	60	3900
	22 MM							
	JMXT-2201BFS	46.0 mm 1.81 in	16.2 mm 0.64 in	17.4 mm 0.68 in	12.8 mm 0.50 in	50	60	3000
	25 MM							
	JMXT-2535BGR	58.0 mm 2.28 in	12.1 mm 0.47 in	18.7 mm 0.73 in	N/A	35	60	1400
	JMXT-2542BGR	62.0 mm 1.69 in	8.3 mm 0.33 in	17.1 mm 0.67 in		35	60	1400
	JMXT-2501BGR	63.0 mm 2.48 in	16.2 mm 0.64 in	17.4 mm 0.68 in	12.8 mm 0.50 in	35	60	1400

Trenching

	Part Number Product Code	G - Gauge (mm, in)	A - Base Diameter (mm, in)	B - Tip Height (mm, in)	C - Tip Diameter (mm, in)	Pieces per Box	Boxes per Pallet	Pieces per Pallet
	25 MM							
	JMXT-2574CC	63.0 mm 2.48 in	18.0 mm 0.70 in	24.0 mm 0.94 in	11.0 0.43 in	15	60	600
	JMXT-2523CC	64.0 mm 2.51 in	24.7 mm 0.97 in	23.8 mm 0.93 in	17.3 mm 0.68 in	15	60	600
	38/30 MM							
	JMXT-3874CC	76.0 mm 2.99 in	18.0 mm 0.70 in	24.0 mm 0.94 in	11.0 mm 0.43 in	10	60	400

Blocks

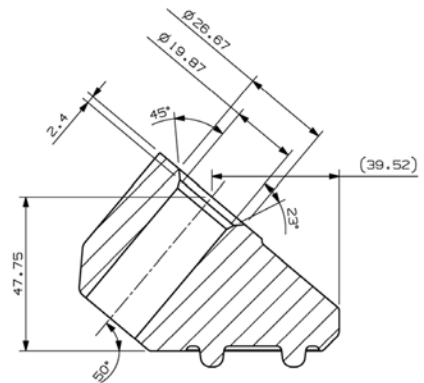
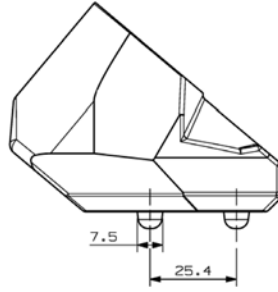
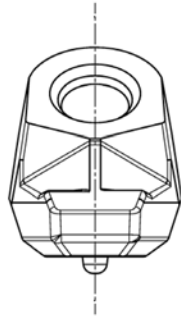

Standard Block

Part Number/Product Code	Bore Hole Dimension	Pieces per Box	Boxes per Pallet	Pieces per Pallet
JMxB-19S	19mm - straight bore	35	60	2100

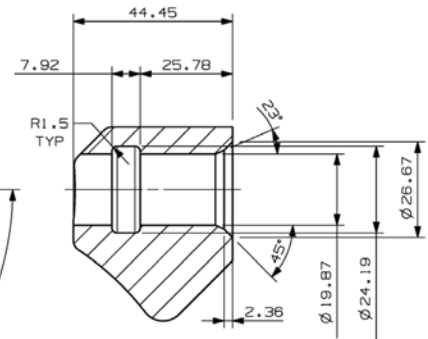
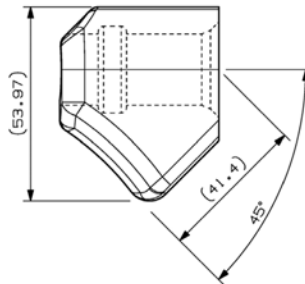
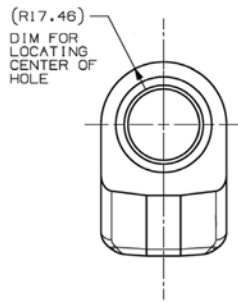
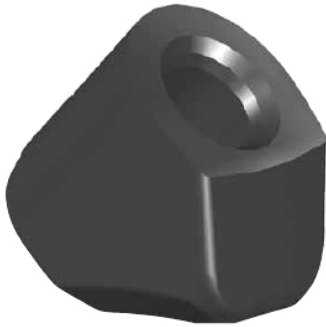

Heavy Duty Block

Part Number/Product Code	Bore Hole Dimension	Pieces per Box	Boxes per Pallet	Pieces per Pallet
JMxB-19H	19mm - straight bore	35	60	2100

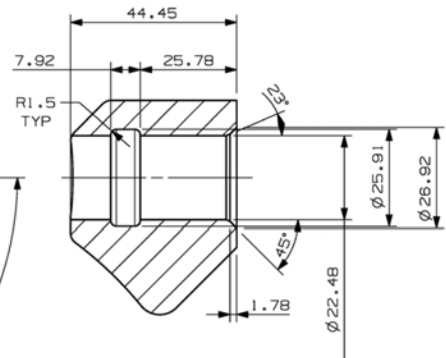
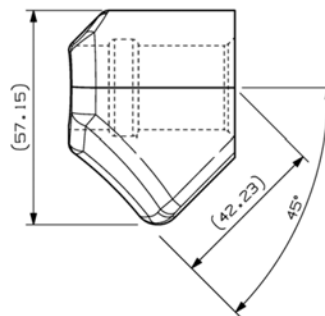
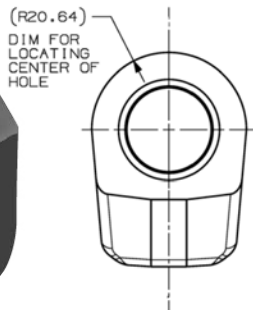
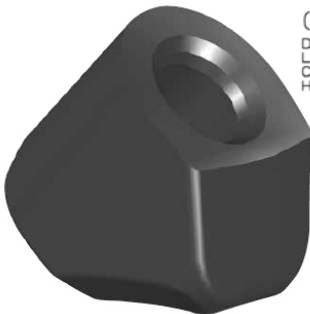

Heavy Duty Block

Part Number/Product Code	Bore Hole Dimension	Pieces per Box	Boxes per Pallet	Pieces per Pallet
JMxB-22H	22mm - straight bore	35	60	2100

Blocks

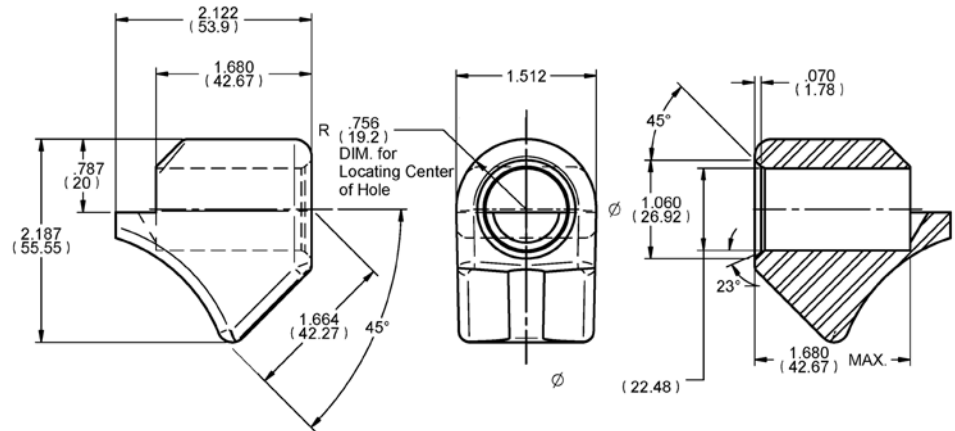

A unique block design used to create a combination chain for rotating and non-rotating tools

Part Number/Product Code	Bore Hole Dimension	Pieces per Box	Boxes per Pallet	Pieces per Pallet
JMXB-22N	22mm - straight bore	35	60	2100

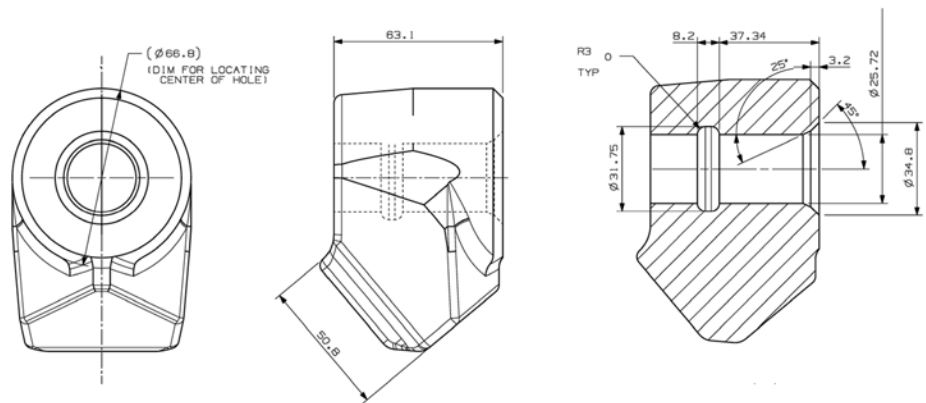

A heavy-duty block with shorter base for compact positioning

Part Number/Product Code	Bore Hole Dimension	Pieces per Box	Boxes per Pallet	Pieces per Pallet
JMXB-25HS	25mm - straight bore	8	60	480

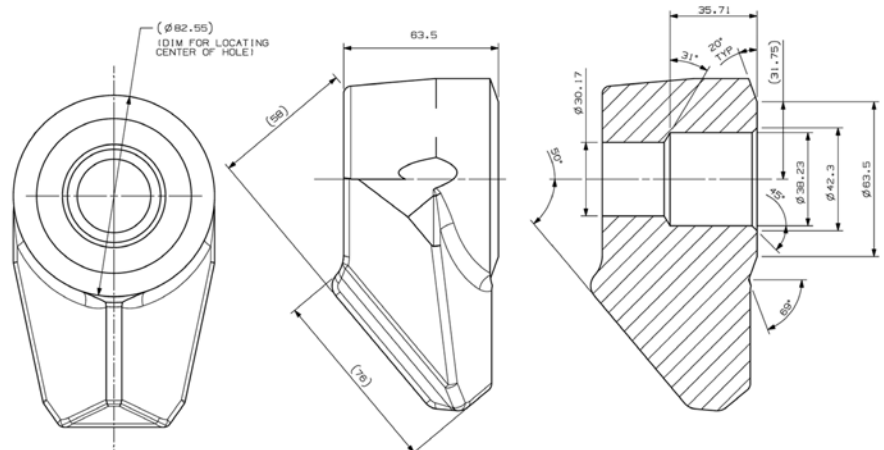

A heavy-duty block that features a "V" design, which provides greater surface-weld area

Part Number/Product Code	Bore Hole Dimension	Pieces per Box	Boxes per Pallet	Pieces per Pallet
JMXB-38H	30/38mm - stepped bore	8	60	480

Blocks

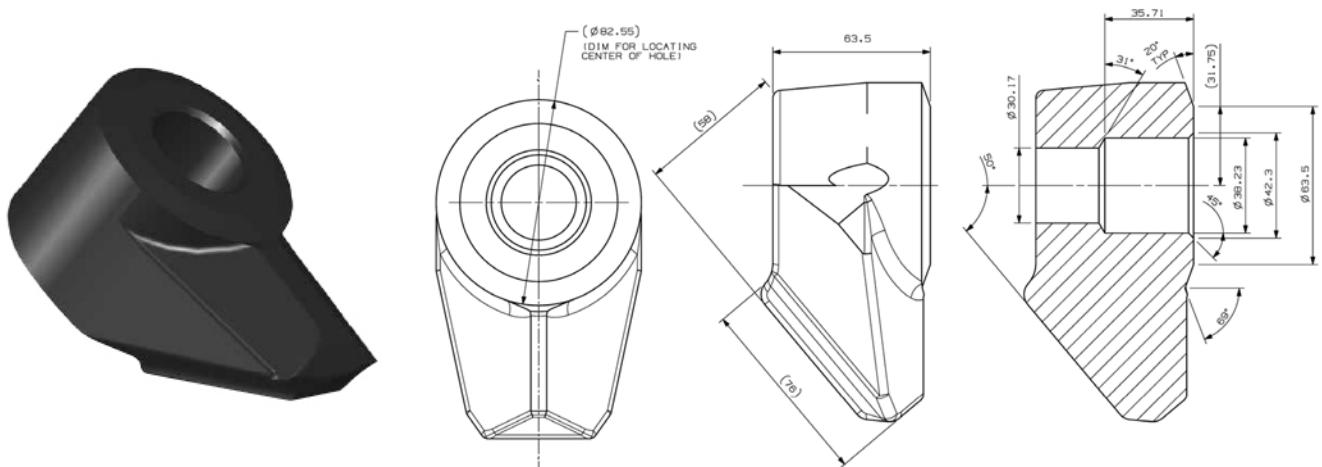

A heavy-duty block that features a “V” design, which provides greater surface-weld area

Part Number/Product Code	Bore Hole Dimension	Pieces per Box	Boxes per Pallet	Pieces per Pallet
JMXB-38HV	30/38mm - stepped bore	6	60	360

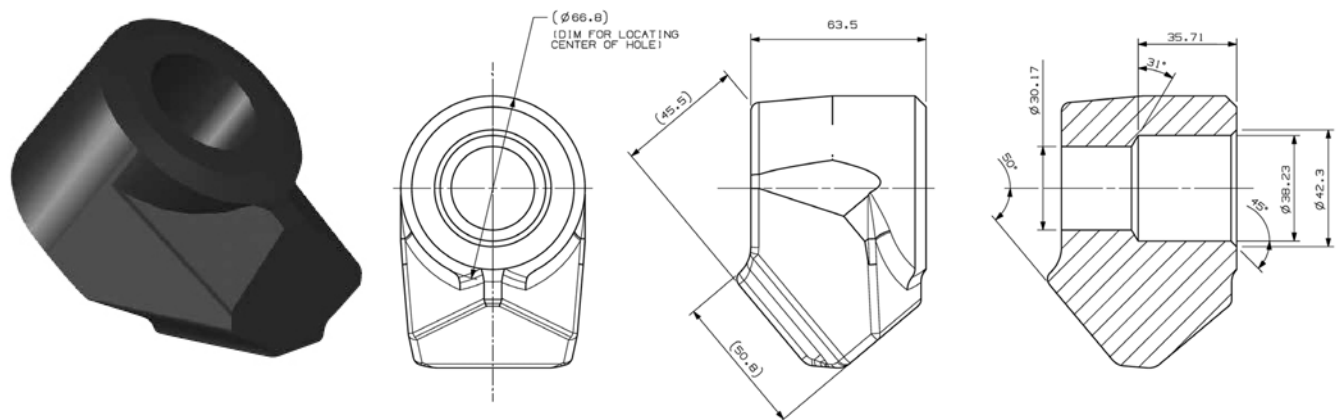

A heavy-duty block with shorter base for compact positioning

Part Number/Product Code	Bore Hole Dimension	Pieces per Box	Boxes per Pallet	Pieces per Pallet
JMXB-38HSS	30/38mm - stepped bore	6	60	360

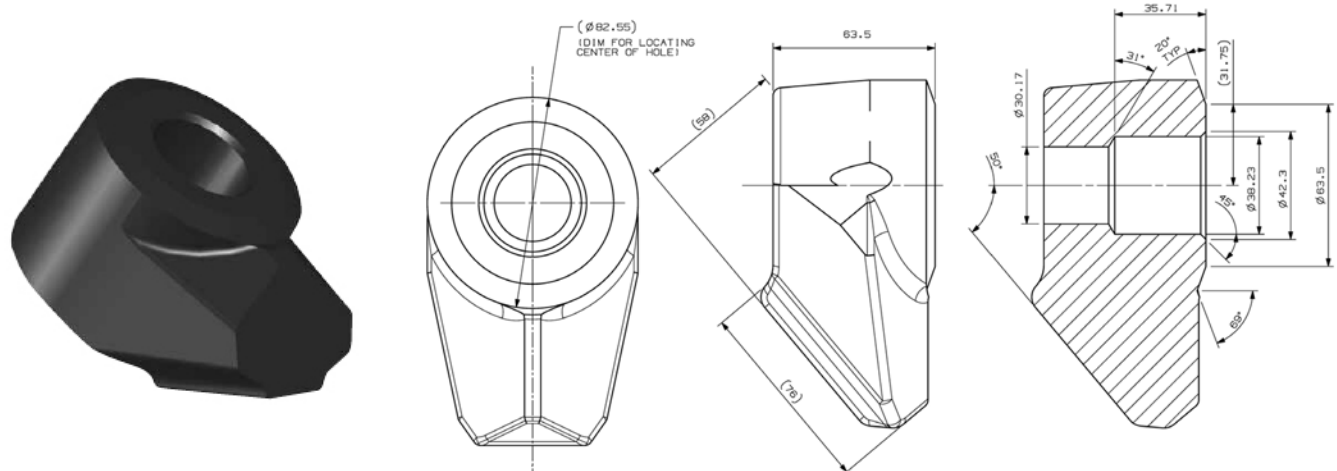

A heavy-duty block with shorter base for compact positioning

Part Number/Product Code	Bore Hole Dimension	Pieces per Box	Boxes per Pallet	Pieces per Pallet
JMXB-38HST	30/38mm - stepped bore	6	60	360

Accessories



FORKED PULLER - For removal of tools with 19mm shank.

Part Number
Product Code

JMXA-FP19



FORKED PULLER - For removal of tools with 22mm shank.

Part Number
Product Code

JMXA-FP22



FORKED PULLER - For removal of tools with 25mm shank.

Part Number
Product Code

JMXA-FP25

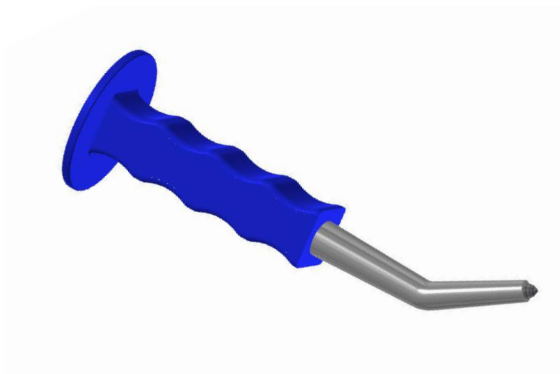

CURVED KNOCK OUT PUNCH - Tool remover with carbide tip for extended life

Part Number
Product Code

JMXB-CKP

Accessories

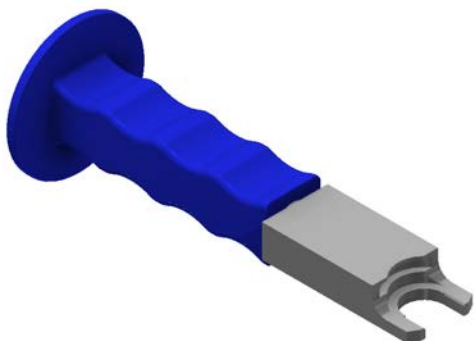

INSTALLATION/REMOVAL - For removal of external hairpin retainers 25mm shank.

Part Number
Product Code

JMXA-CC25

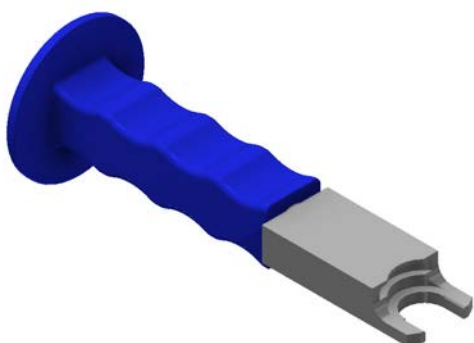

INSTALLATION/REMOVAL - For removal of c-clip 30mm shank.

Part Number
Product Code

JMXA-CC30

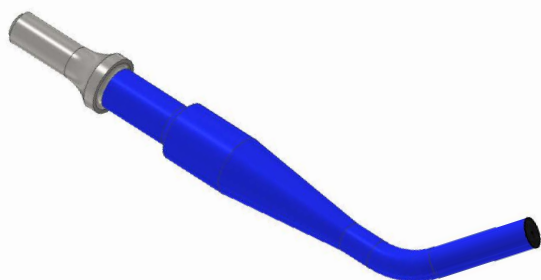

AIR HAMMER PUNCH - 3/8" chuck.

Part Number
Product Code

JMXA-AH38



AIR HAMMER PUNCH - 1/2" chuck.

Part Number
Product Code

JMXB-AH12

Part Number Reference Guide

Use this chart to cross reference SANDVIK part number to our XCAL TOOLS part numbers.

SANDVIK Part Number - Product Code	XCAL TOOLS Part Number - Product Code
Drilling	
H1MA-1944-0169	JMXD-1901FSR
H1MA-2243-0169	JMXD-2201FSR
P0DS-3888-0862	JMXD-3808SR
P3DX-3863-2062	JMXD-3820SR
Trenching	
K9MA-2245-0169	JMXT-2201BFS
P9QA-2563-0169	JMXT-2501BGR
P3PD-2563-2362	JMXT-2523CC
P9QA-2560-3562	JMXT-2542BGR
P9QA-2561-4262	JMXT-2574CC
P3PD-2563-7462	JMXR-668HD
H2MA-1846-0169	JMXT-1801BGR
H2MA-1946-0169	JMXT-1901BGR
Q3DD-3876-7462	JMXT-3874CC
Blocks	
B3AH-1943-4500	JMXB-19H
B3AH-2243-4500	JMXB-22H
B3AA-1943-4500	JMXB-19S
B4BJ-2246-4500	JMXB-22T
B3DH-3874-5000	JMXB-38H
B4BA-1948-5000	JMXB-19L
B3DH-3880-5000	JMXB-38HV
B3DI-3874-5000	JMXB-38HSS
B3DI-3880-5000	JMXB-38HST
B3AI-2574-5000	JMXB-25HS
B1XX-2239-4500	JMXB-22N

Part Number Reference Guide

Use this chart to cross reference SANDVIK part number to our XCAL TOOLS part numbers.

SANDVIK Part Number - Product Code	XCAL TOOLS Part Number - Product Code
Road Milling and Reclaiming	
K6FT-1949-6866	JMXR-XTEND-68
K6FW-1949-8466	JMXR-684
K6FW-1949-7966	JMXR-779
K6FW-1949-6866	JMXR-668
K6FW-1949-2966	JMXR-529
K6FW-1949-2766	JMXR-727
K6FW-1949-2666L	JMXR-526
K6FW-1949-2666	JMXR-425
K6FW-2249-2966	JMXR-2229
K6FW-2249-0366	JMXR-2203
R6XJ-2251-XX63	JMXR-22XX
K6HT-1949-2766	JMXR-XTEND-27HD
K6HW-1949-8666	JMXR-786HD
K6HW-1949-7966	JMXR-779HD
K6HW-1949-6866	JMXR-668HD
K6HW-1949-2766	JMXR-727HD
K6FW-1949-0366	JMXR-614
K6FT-1949-8466	JMXR-XTEND-84
Grading	
K1LS-2244-0169	JMXG-2201
K1LS-2244-2766	JMXG-2227
K1LS-2244-2869	JMXG-2228
K1LW-2244-2869	JMXG-2228W
K9LW-2244-7062	JMXG-2270W
K1LW-2557-2362	JMXG-2523W
K1LW-2557-1362	JMXG-2513W
Q7JZ-3574-2062	JMXG-3520W

